

# Quantometer MZ

## Turbine Gas Meter

MZ meters are flow meters. The flow of gas turns the turbine wheel, and thus the rotating speed of the turbine is proportional to the linear speed of the gas. The movement is mechanically transmitted to the totaliser through a magnetic coupling.

### Key Benefits

- » High accuracy budget meter
- » Flow rate up to 2500 m<sup>3</sup>/h
- » Pressure range up to 40 bar
- » Equipped as standard with the cycle target
- » Various options available: Low and high frequency transmitters, thermowell, oil pump, version for aggressive gases, etc

### Applications

MZ meters are designed to measure natural gas, and various filtered, and non-corrosive gases.

They are used to measure low to medium and high flow, at low or medium, or high pressure.

They have been especially designed

for industrial use and for secondary measurement.

The possibility of fitting various options such as the oil pump or the PTFE coating version, means that they are also suitable for use in heavy duty measurement.

### Description

- 1 a body part containing all the components
- 2 a flow straightener to stabilise and accelerate the flow before the turbine wheel
- 3 a measuring unit including the turbine wheel
- 4 a magnetic coupling to transmit the movement of the turbine wheel to the totaliser
- 5 a totaliser to register the measured gas

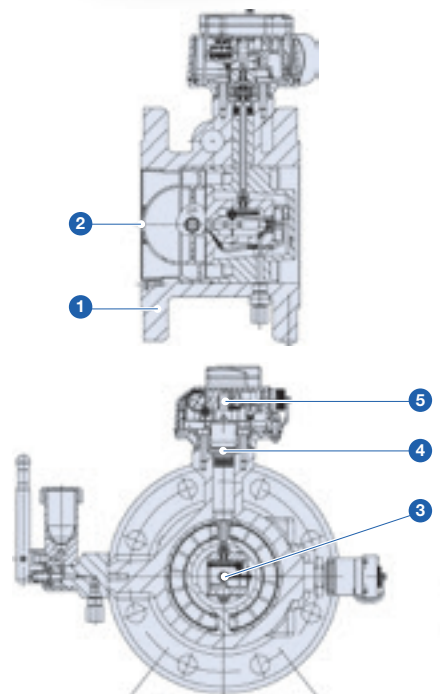

### Technical Specifications

|                          |  |                |
|--------------------------|--|----------------|
| Flow Rate                | From 6 m <sup>3</sup> /h to 2500 m <sup>3</sup> /h                         |                |
| Nominal Diameters        | From DN 2" to 8", DN50 to DN200  |                |
| Material                 | Ductile iron<br>Compliant with the Pressure Equipment Directive 2014/68/EU |                |
| Maximum Working Pressure | Up to 40 bar depending on flanging   |                |
| Temperature Range        | Ambient:   | -30°C to +60°C |
|                          | Gas:   | -30°C to +60°C |
|                          | Storage temperature:   | -40°C to +70°C |
| Metrology                | The tolerance of acceptance is +/-1.5% from Qmin to Qmax.                  |                |



Quantometer MZ DN150, Qmax: 1600 m<sup>3</sup>/h



Universal totaliser fitted as standard with the Cyble target



### Typical calibration curve

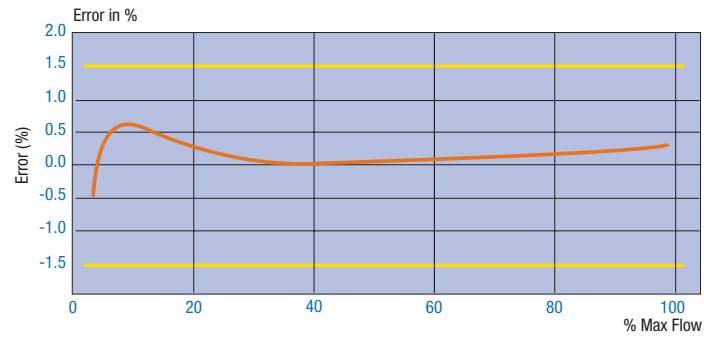

### Totaliser:

- » 9-digit index to register a larger volume
- » 45° orientation for an easy reading
- » Equipped as standard with the cyble target: it allows the installation of the cyble sensor at any time
- » Free-rotating totaliser
- » Equipped with 1 built-in silicagel cartridge
- » Fitted with a reflecting disc on the first drum
- » IP67 protection
- » UV resistant cover
- » Unit: m<sup>3</sup>

### Transmitters

- 1 Cyble sensor: it can be delivered mounted onto the meter or installed afterwards at any time.  
The Cyble sensor is a bounce-free transmitter. It allows also the counting of eventual back flows.
- 2 Low Frequency (LF): two Reed switches are fitted as standard on the whole range.  
Anti-tampering (AT): this device is fitted as standard on the whole range.
- 3 Medium Frequency (MF): one transmitter is supplied as an option.
- 4 High Frequency (HF): a transmitter is supplied as an option, and it is fitted close to the turbine wheel.

### Oil pump

- 5 It lubricates the ball bearings in the measuring unit.  
The oiling can be done even when the meter is under pressure.  
The oil reservoir can be easily turned to fit with vertical installed meters.

### Pressure tapping:

This device allows the gas pressure to be measured at the reference point. It is installed as standard.

### Measurement of aggressive gases:

A version with a PTFE (Teflon) coating, is available, as an option. The coating is applied on the internal parts of the meter.

### Turbine wheel

- 6 This is the most important component of the meter for achieving high accuracy at low and high pressure. Depending on the maximum flow rate, the blade of turbine wheel is oriented at 45° or 60°. Turbine wheel at 60° is used to avoid over-speed of the wheel.

### Thermowell

- 7 A thermowell can be installed as an option into the meter. It allows the gas temperature to be measured at the reference point.  
(Installation of a thermowell cannot be done into a meter equipped with HF transmitter)

### Volume converter

- 8 It can be installed directly onto the meter thanks to a mounting kit

# Characteristics

## A) Technical data sheet

### Rangeability and pulse values

| DN<br>(mm) | Max Flow<br>(m <sup>3</sup> /h) | Min Flow<br>(m <sup>3</sup> /h) | Pressure loss<br>(mbar)<br>$\rho = 0.8 \text{ kg/m}^3$ | 1 Imp LF<br>& Cyble<br>(m <sup>3</sup> /Imp) | Freq LF Qmax<br>(Hz) | With correction gears 32/40 (correction 0%) |                      |                                    |                      |
|------------|---------------------------------|---------------------------------|--|--|----------------------|---|----------------------|------------------------------------|----------------------|
|            |                                 |                                 |  |  |                      | 1 Imp MF<br>(dm <sup>3</sup> /Imp)          | Freq MF<br>Qmax (Hz) | 1 Imp HF<br>(dm <sup>3</sup> /Imp) | Freq HF Qmax<br>(Hz) |
| 50         | 100                             | 6                               | 8.1  | 0.1  | 0.28                 | 5.8947                                      | 4.71                 | 0.00970                            | 2864                 |
| 80         | 250                             | 10                              | 4.8  | 1  | 0.07                 | 23.07692                                    | 3.01                 | 0.03797                            | 1829                 |
|            | 400                             | 25                              | 11   | 1  | 0.11                 | 39.11111                                    | 2.84                 | 0.06434                            | 1727                 |
| 100        | 400                             | 16                              | 4.8  | 1  | 0.11                 | 23.07692                                    | 4.81                 | 0.06271                            | 1772                 |
|            | 650                             | 40                              | 11   | 1  | 0.18                 | 39.11111                                    | 4.62                 | 0.10628                            | 1699                 |
| 150        | 1000                            | 40                              | 4.3  | 1  | 0.28                 | 23.07692                                    | 12.04                | 0.15385                            | 1806                 |
|            | 1600                            | 100                             | 9  | 1  | 0.44                 | 39.11111                                    | 11.36                | 0.26074                            | 1705                 |
| 200        | 1600                            | 65                              | 4.3  | 10   | 0.04                 | 230.7692                                    | 1.93                 | -                                  | -                    |
|            | 2500                            | 160                             | 9  | 10   | 0.07                 | 391.1111                                    | 1.78                 | -                                  | -                    |

### Body construction

| DN<br>(mm) | ISO PN 10 | ISO PN 16 | ISO PN 20<br>ANSI 150 | ISO PN 25 | ISO PN 40 |
|------------|-----------|-----------|-----------------------|-----------|-----------|
| 50         | A         | A         | A                     | A         | A         |
| 80         | A         | A         | A                     | A         | A         |
| 100        | B         | B         | B                     | -         | -         |
| 150        | B         | B         | B                     | -         | -         |
| 200        | B         | B         | B                     | -         | -         |

A: EN-GJS-400-18LT Sandwich body (the screws are delivered with the meter)

B: EN-GJS-400-18LT flanges body

Note: for the pressure and temperature range of the body material, please check your National Rules

## B) Calculation of the extended rangeability

When the density of the measured gas increases, the minimum measured flow rate decreases. This minimum flow rate in real conditions (QminRC) can be evaluated using the following formula:

Qmin<sub>1,2</sub>: minimum flowrate (m<sup>3</sup>/h) for a density of 1.2 kg/m<sup>3</sup>

$\rho_{RC}$ : density of the gas in real conditions (kg/m<sup>3</sup>)

$$Q_{min_{RC}} = Q_{min_{1,2}} \times \sqrt{\frac{1.2}{\rho_{RC}}}$$

### where:

$\Delta p$ : Pressure loss in the calculated conditions

$\Delta p_r$ : Pressure loss in the reference conditions

$\rho_n$ : Gas density (kg/m<sup>3</sup>) at 0° C and 1013 mbar

Pb: Operating pressure (Bar gauge)

q: Flow rate (m<sup>3</sup>/h)

Qmax: Maximum flow rate (m<sup>3</sup>/h)

Tb: Gas temperature (°C).

## C) Pressure loss of the MZ meters Values: see table above

Calculation of pressure loss: 
$$\Delta p = \Delta p_r \times \frac{\rho_n}{0.83} \times (P_b + 1) \times \left[ \frac{q}{Q_{max}} \right]^2 \times \left[ \frac{273}{(273 + T_b)} \right]$$

## D) Dimensions (mm) and Weights

| DN  | L   | A  | B  | ISO PN 10 - ISO PN 40<br>ANSI 150 |     |     | Kg |
|-----|-----|----|----|-----------------------------------|-----|-----|----|
|     |     |    |    | C                                 | D   | E   |    |
| 50  | 60  | 15 | 18 | 156                               | 160 | 163 | 4  |
| 80  | 120 | 35 | 34 | 173                               | 180 | 176 | 10 |
|     |     |    |    | ISO PN 10 - ISO PN 16<br>ANSI 150 |     |     |    |
| 100 | 150 | 54 | 28 | 209                               | 180 | 186 | 19 |
| 150 | 200 | 71 | 48 | 238                               | 225 | 216 | 33 |
| 200 | 200 | 69 | 43 | 273                               | 250 | 277 | 85 |

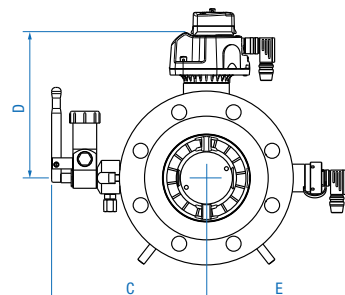
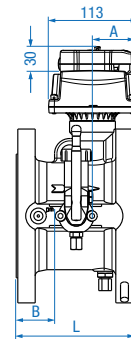

## E) Transmitter characteristics

### Low Frequency pulse transmitters (LF):

The LF transmitter consists of 2 dry Reed switches, normally open, and controlled by a magnet situated in the first drum of the totaliser. The LF connections are without polarity.

### Inductive transmitters (HF and MF):

They are inductive sensors actuated by a toothed disc. The frequency is proportional to the instantaneous flow. The polarity of the connections is indicated on the name plate of the meter.

### Anti-tampering transmitter (AT):

This consists of one dry Reed switch, normally closed. Attempts at magnetic tampering will open the contact. The electrical characteristics are the same as those for the LF transmitter.

## F) Installation

Each meter is delivered with binder plugs for the installed transmitters and oil when an oil pump is installed. Please refer to the instruction manual supplied with the meter.

The advice given therein will ensure optimal use of the MZ quantometer over the years.

### Actaris Gas Measurement

Hardeckstr 2,  
76185 Karlsruhe  
T: +49 (0)721 / 5981 - 100  
F: +49 (0)721 / 5981 - 282

© 2022 Natural Gas Solutions North America, LLC – All rights reserved.  
Dresser Utility Solutions reserves the right to make changes in specifications and features shown herein, or discontinue the product described at any time without notice or obligation. Contact your Dresser Utility Solutions representative for the most current information. The Dresser Logo and all Trademarks containing the term "Dresser" are the property of Dresser, LLC, a subsidiary of Baker Hughes.

